



Literature review of gear-based management options in the Caribbean for four reef fishing methods: fish traps, spears, hook and line, and beach seines

Reef fisheries provide a vital source of income and food to millions of people worldwide. Reef fishes are important to many countries in the Caribbean not only for their value to the fisheries, but also their value to the tourism industry, where they are an important part of the snorkeling and diving experience. Many Caribbean reef fisheries have been overexploited for decades and often their decline has been accelerated by a loss of habitat. Improved management of Caribbean reef fisheries is vital to ensure their future sustainability.

Reef fisheries in the Caribbean are difficult to manage due to the use of multiple fishing gear types, the number of species harvested, and the dispersed landing sites used by the fishers. Additionally, there is very little published information available on Caribbean reef fisheries and limited research into the effects of management. This review provides a synthesis of the published literature on four gears commonly used in Caribbean reef fisheries: fish traps, spears, hook and line, and beach seines, summarizing evidence on best management practices for each gear. We provide brief descriptions of each of the four gear types as well a synthesis of their use, biological impacts, and ecosystem impacts. The management recommendations summarized below are general recommendations on gear restrictions that could be applied to any Caribbean reef fishery.

Key recommendations for fish traps:

-) Minimum mesh size 3.8 cm (1.5 inch), with larger minimum mesh sizes phased in depending on local target species – to reduce catch of juvenile fish and optimize size of target species caught.
-) Mandatory escape gap (or gaps) in all fish traps - to reduce catch of juveniles and bycatch species. Two 20 x 2.5 cm gaps are one option.
-) Mandatory inclusion of escape panels (door held in place with biodegradable fastener) in all fish traps - to reduce the impact of ghost fishing
-) Fish traps not to be set on live coral, seagrass and other sensitive habitats – to avoid damage to corals, seagrasses and other benthic organisms
-) Landing-site gear disposal bins and incentive programs - to reduce disposal of damaged or unwanted gear at sea

Key recommendations for spearfishing:

-) Ban spearfishing on scuba – to avoid rapid depletion of reef fish stocks
-) Ban spearfishing at night – to avoid rapid depletion of reef fish stocks
-) Consider total ban if dive tourism is a major income source – to avoid depletion of larger fishes and reductions in fish diversity

Key recommendation for hook and line:

-) If there is significant bycatch that is released, replace J-hooks with circle hooks – to reduce injury and mortality to released bycatch

Key recommendations for beach seines:

-) Ban beach seine use on or near coral reefs and seagrass habitats – to avoid damage to these sensitive habitats
-) Minimum mesh size 3.8 cm (1.5 inch) – to reduce proportion of juvenile fish in catch

Contents

Introduction	4
Fish traps.....	5
Description of gear and use	5
Biological and ecosystem impacts	9
Management options.....	9
Mesh size.....	9
Escape gaps	10
Escape panels.....	11
Gear retrieval	12
Spearfishing.....	13
Description of gear and use	13
Biological and ecosystem impacts	13
Management options.....	14
Lionfish spearfishing – new opportunities.....	14
Hook and line	15
Description of gear and use	15
Biological and ecosystem impacts	15
Management options.....	16
Beach Seine.....	16
Description of gear and use	16
Biological and ecosystem impacts	17
Management options.....	17
References	17

Introduction

Maintaining coral reef fisheries productivity in a world where reefs are subject to multiple impacts is of major importance to the estimated 6 million coral reef fishers worldwide who rely on these fisheries for income and food (Teh et al., 2013). Reef fishes provide economic benefits to tourism, with tourists willing to pay to see abundant, diverse, and large reef fish (Gill et al., 2015; Uyarra et al., 2005). Beyond these direct economic benefits, maintaining functional reef fish communities is vital for the resilience of coral reefs (Bozec et al., 2016; Graham et al., 2013). Coral reefs provide shoreline protection services with an estimated value between \$944 million to \$2.8 billion in the Caribbean alone (Burke et al., 2011). Retaining functional reef fish communities while balancing the demands of the coastal communities that depend upon the reefs is an ongoing challenge for reef managers.

Reef fisheries exploit multiple species with multiple fishing gear types (Hicks and McClanahan, 2012; McClanahan and Cinner, 2008), with catches often landed at many dispersed sites (Mahon, 1997). This diversity of target species, gear types, and landing locations complicates fisheries monitoring and management. Implementing marine protected areas (MPAs) is an increasingly popular way to meet both conservation and fisheries management goals for coral reefs (Beger et al., 2015; Gaines et al., 2010). However, gear-based management is often more readily accepted by artisanal reef fishing communities (McClanahan et al., 2008; McClanahan and Mangi, 2004). In practice, managers use a mix of MPAs and gear-based management for many reef fisheries (McClanahan, 2010). Gear restrictions can be tailored to address specific fisheries issues. For example, restrictions or bans on certain gear types can protect against habitat damage or harvesting of certain species (Cinner et al., 2009; Mangi and Roberts, 2006; McClanahan and Mangi, 2004).

Reef fisheries in the Caribbean have been heavily depleted by past and recent overfishing (Jackson et al., 2014; Jackson, 1997), and ensuring their future sustainability is a high priority (Salas et al., 2007). Although many countries within the Caribbean already have some regulations on the use of fishing gear (McManus and Lacambra, 2005), there is little published advice on what gear-based management options are available. This review aims to provide an outline of four common fishing gear types used on and near Caribbean reefs (fish traps, spears, hook and line, and beach seines) and includes a summary of current understanding of the biological and ecosystem impacts of these gears and the management options available. We focus specifically on gear restrictions, such as minimum mesh sizes for traps and nets, and bans on the use of gears in certain habitats. There are many other management options available that can be used in combination with these measures, such as minimum landing sizes, individual quotas, and marine reserves.

Fish traps

Description of gear and use

Fish traps were the predominant gear in Caribbean reef fisheries 15 years ago (Fig. 1; Mahon and Hunte, 2001; Munro, 1983), and this is still the case on many islands today (CRFM, 2014). Traps are popular with reef fishers within the Caribbean as they are relatively simple and inexpensive to make (Garrison and Beets, 1998). They can be used on rugged substrates where other gears might be damaged (Miller and Hunte, 1987). Also, they catch fish without the fisher having to attend them and, as such, can be left at sea in inclement weather (Hawkins et al., 2007). The most frequently used traps are the Antillean Z-trap and the arrowhead or chevron trap (Mahon and Hunte, 2001) (Figure 2). S-traps and rectangular traps are also in use, mainly in Cuba and Puerto Rico, respectively (Mahon and Hunte, 2001).

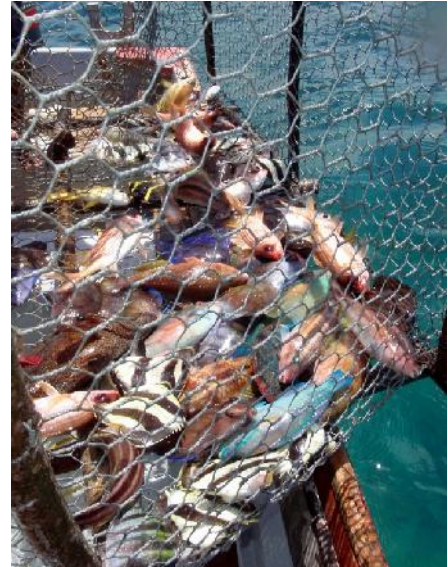

Figure 1. Multi-species trap catch in Barbados. Photo credit: Hazel Oxenford

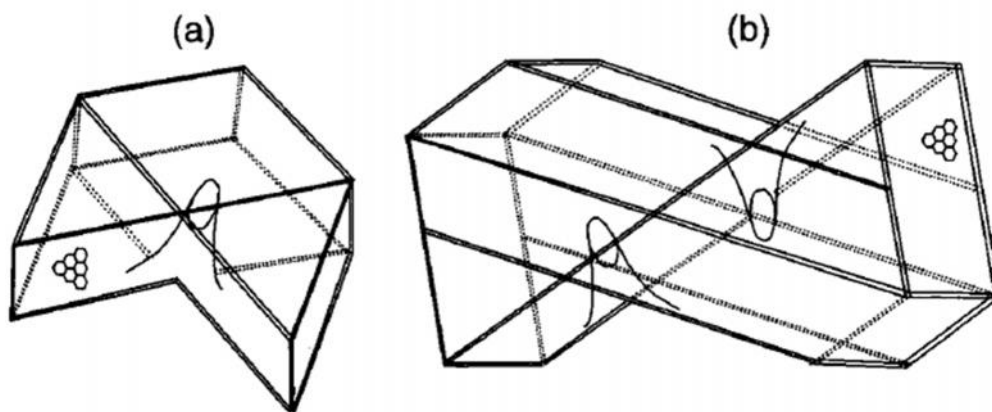

Figure 2. Two most common types of Caribbean fish traps: (a) single funnel arrowhead or chevron trap; (b) the double funnel Antillean Z-trap (from Munro et al., 1971)

Traps are usually set on or near reefs but may also be deployed in deeper waters to catch snappers and groupers found at depth (Mahon and Hunte, 2001). Physical characteristics of the trap, fishing methods, fish biology and ecology, and environmental factors each affect trap catch rates (

The mesh size of a trap plays an important role in determining the size of fish caught and the species composition of catch, likely due to size selectivity (Mahon and Hunte, 2001). Regulation of mesh size is therefore used as a method of reducing the proportion of juvenile fish in trap catches and for increasing

the number of large fish that have greater commercial value (Baldwin et al., 2004; Bohnsack et al., 1989). Given the high diversity of species caught in fish traps, no single mesh size can avoid catching all juvenile fish while also maximizing the yield of every species. The best mesh size to ensure sustainable catches of one target species may still lead to overfishing of other species. The experimental data available on mesh sizes is limited, but the body of evidence suggests that an increase in mesh size to 3.8 cm can result in an increase in catch weight per unit effort in the long term (though this may take a year or more) and a reduction in immature fish in the catch (Mahon and Hunte, 2001; Sary et al., 1997). Increasing mesh size to 5.1 cm can further reduce the proportion of immature fish and may be optimal for some species, e.g. silk snapper (*Lutjanus vivanus*) (Wolf and Chislett, 1974). There are no long-term experiments with 5.1 cm mesh size traps, so it is not known what effects adopting such a mesh size would have on long-term fisheries sustainability. If larger mesh sizes are introduced, a phased introduction of progressively larger sizes can help avoid excessive hardship for fishers due to large reductions in catch in the short term (Mahon and Hunte, 2001).

Most research to determine the effect of mesh size on catches has been conducted where trap fishing already takes place and where the mesh sizes used in the existing fishery are smaller than those being used in the research study (Mahon and Hunte, 2001). Most of these studies find that larger mesh sizes lead to a reduction in catch per trap. However, this result is to be expected given the smaller mesh size traps that fishers use will catch most fish before they reach a size when they could be caught in the larger mesh traps used in experiments. To understand the effect an increase in mesh size would have on catches, it is necessary to modify or replace all (or nearly all) traps in a fishery with the desired mesh size and follow the change in catch over several years.

The only experiments to look at longer-term effects of increased mesh sizes in the Caribbean showed that the mean catch weight per trap per haul for a 1.5 inch (3.8 cm) mesh one year after introduction was almost the same (0.83 kg) as that for the 1.25 inch (3.2 cm) mesh in the previous year (0.79 kg; Sary et al., 1997). Catch for the larger mesh traps increased to 1.24 kg three years after introduction. The mean length of Redband Parrotfish (*Sparisoma aurofrenatum*) was higher in the large mesh traps, indicating that the catch of juveniles and smaller individuals of this species was reduced (Sary et al., 1997).

Escape gaps

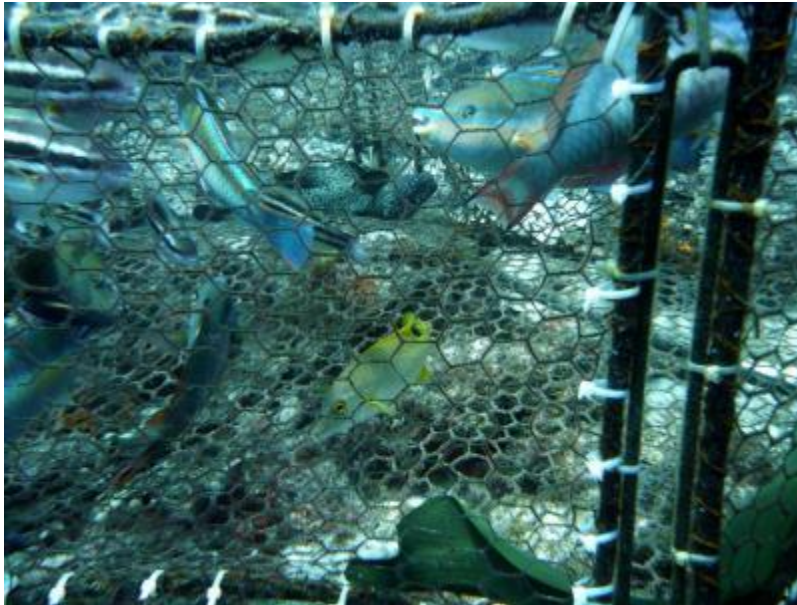

*Figure 3. View of trap underwater with escape gap visible on the right hand-side of the image.
Photo: <https://www.rare.org/stories/2011-solution-search-winners>*

Compared to mesh size, relatively little research has been published on the effects of escape gaps on trap catches (Johnson, 2010; Munro et al., 2003). Escape gaps are narrow slits that are built into a trap (Figure 3), with tested sizes varying from short gaps, e.g. 7 x 2.5 cm, to taller gaps, e.g. 40 x 2.5 cm, and widths varying from 2 cm to 8 cm (Baldwin et al., 2004; Condy et al., 2015; Johnson, 2010). The use of escape gaps offers a complementary or alternative approach to increased mesh size by adjusting the size selectivity of traps and allowing juveniles and narrow-bodied fish to escape. The few research studies that have evaluated the use of escape gaps have found the value of catches may be maintained or reduced in the short-term and increased in the longer-term.

The most recent Caribbean study, in Curaçao, tested short escape gaps (20 x 2.5 cm) and tall escape gaps (40 x 2.5cm). Both sizes resulted in decreased catches of key herbivores (-58% and -50%, respectively) and bycatch species, such as butterflyfish and damselfish (-74% and -80%), and increases in the mean length of fish caught (Johnson, 2010). Furthermore, no significant reduction in the catch of high-value fish or market value of the catch was found with these escape gaps, though mean weight of the total catch was reduced.

These results are generally consistent with two studies based in Kenya that examined the performance of traps with escape gaps of varying sizes (Condy et al., 2015; Gomes et al., 2014). Both Kenya studies found reductions in the abundance of juvenile fish in the catch and an increased proportion of more commercially valuable adult species. One of these studies predicted a decline in profitability in the first year if escape gaps were implemented, with an increase in following years (Condy et al., 2015). The second study found no change in value of the catch in heavily fished areas and an increase in value in less depleted areas (Gomes et al., 2014).

Escape panels

In some fisheries 20-30% of traps are lost, abandoned, or discarded per year (NOAA Marine Debris Program, 2015), resulting in millions of ghost fishing traps worldwide (Scheld et al., 2016). Escape panels, which are weighted panels with a biodegradable fastener, have emerged as the best option for reducing the impacts of ghost fishing by traps (Stewart, 2007; Selliah et al., 2001; Fig. 4). Hemp twine has been shown to be the most suitable material for the fastener within the Caribbean (Selliah et al., 2001). Escape panels tied with hemp twine and weighted to help the panel fall open, opened after 22 - 26 days during testing (Selliah et al., 2001).

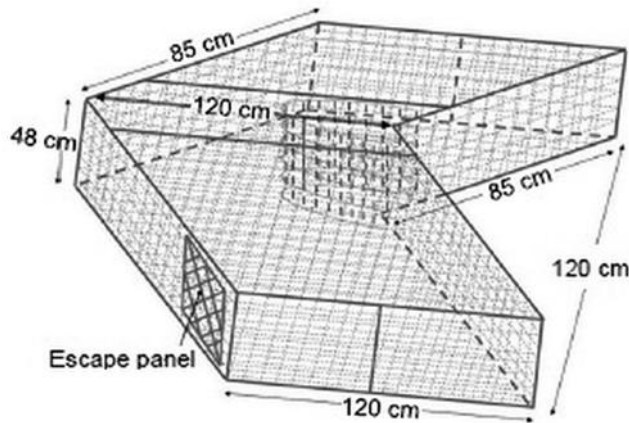

Figure 4. Arrowhead trap showing escape panel (after Renchen et al. 2014)

The only Caribbean study on the effects of trap ghost fishing took place in the U.S. Virgin Islands (U.S.V.I.) and documented a 2% mortality rate for trapped fish (Renchen et al., 2014). Another study in Florida, not specifically focused on ghost fishing, found that 27% of fish were dead or injured in traps left for 20 days, and 17% of fish in traps left for two months were dead or injured (Taylor and McMichael, Jr., 1983). Neither experiment includes estimates of fish mortality through predation and scavenging within the cage, which may be a significant (Munro et al., 1971; Rassweiler and Rassweiler, 2011). Estimates of trap losses are variable with 10% of traps estimated to be lost each year in the U.S.V.I. (Renchen et al., 2014) and 15-20% lost per 20-day trip in the Tortugas, Florida (Taylor and McMichael, Jr., 1983). The use of escape panels was found to reduce fish mortality to near zero (Renchen et al., 2014). Escape panels are required by law in all traps used in Barbados (Baldwin et al., 2004), Curaçao, Puerto Rico and the U.S. Virgin Islands (NOAA, CFMC, 2015).

). Traps catch a high diversity of reef fish, with as many as 90 species and 35 families recorded in the Caribbean over multiple trap hauls (Jiménez and Sadovy, 1996), including species from most reef fish families. Snappers (Lutjanidae) and groupers (Serranidae) are typically the target species for Caribbean reef fisheries, but the Caribbean-wide depletion of these fish families has resulted in 'fishing down the food web', with increasing proportions of lower trophic level species such as parrotfish (Scaridae) and surgeonfish (Acanthuridae) being targeted (Garrison and Beets, 1998; Johnson, 2010).

Table 1. Trap characteristics that can affect catch rates and species composition of catch (principally from Mahon & Hunte 2001)

Physical characteristics	Fishing method	Fish biology and ecology	Environmental factors
<ul style="list-style-type: none">) Mesh size) Trap design) Trap size) Escape gaps 	<ul style="list-style-type: none">) Soak time*) Depth) Bait) Location of traps 	<ul style="list-style-type: none">) Fish behavior) Predation) Mobility and activity of fishes) Body size and shape of fishes 	<ul style="list-style-type: none">) Moon phase) Shelter provided by trap) Visibility

*Length of time traps are left underwater before fish are harvested

Biological and ecosystem impacts

For fisheries managers, traps present a considerable challenge as they can impact fish stocks and ecosystems in a number of different ways. First, the small mesh sizes that are frequently used in traps result in the capture of juvenile fishes. Second, traps have poor selectivity – they will retain any fish that enters the trap and is not able to find its way back out of the entrance funnel or escape through the mesh. This indiscriminate harvest results in high catch diversity and the capture of many species that are not of commercial interest. Third, fish traps catch herbivorous fish, including parrotfish (Scaridae) and surgeonfish (Acanthuridae), which play a vital role in facilitating coral growth and recovery by controlling the abundance of macroalgae on reefs (Mumby, 2006; Mumby and Harborne, 2010). Fourth, traps themselves can cause direct physical damage to habitats, such as scarring or breaking corals (Marshak et al., 2007). Finally, traps are frequently lost or abandoned. These traps will continue to catch fish for as long as their physical structure is intact (called “ghost fishing”), contributing to fish mortality rates.

Management options

Mesh size

The mesh size of a trap plays an important role in determining the size of fish caught and the species composition of catch, likely due to size selectivity (Mahon and Hunte, 2001). Regulation of mesh size is therefore used as a method of reducing the proportion of juvenile fish in trap catches and for increasing the number of large fish that have greater commercial value (Baldwin et al., 2004; Bohnsack et al., 1989). Given the high diversity of species caught in fish traps, no single mesh size can avoid catching all juvenile fish while also maximizing the yield of every species. The best mesh size to ensure sustainable catches of one target species may still lead to overfishing of other species. The experimental data available on mesh sizes is limited, but the body of evidence suggests that an increase in mesh size to 3.8 cm can result in an increase in catch weight per unit effort in the long term (though this may take a year or more) and a reduction in immature fish in the catch (Mahon and Hunte, 2001; Sary et al., 1997). Increasing mesh size to 5.1 cm can further reduce the proportion of immature fish and may be optimal for some species, e.g. silk snapper (*Lutjanus vivanus*) (Wolf and Chislett, 1974). There are no long-term experiments with 5.1 cm mesh size traps, so it is not known what effects adopting such a mesh size would have on long-term fisheries sustainability. If larger mesh sizes are introduced, a phased

introduction of progressively larger sizes can help avoid excessive hardship for fishers due to large reductions in catch in the short term (Mahon and Hunte, 2001).

Most research to determine the effect of mesh size on catches has been conducted where trap fishing already takes place and where the mesh sizes used in the existing fishery are smaller than those being used in the research study (Mahon and Hunte, 2001). Most of these studies find that larger mesh sizes lead to a reduction in catch per trap. However, this result is to be expected given the smaller mesh size traps that fishers use will catch most fish before they reach a size when they could be caught in the larger mesh traps used in experiments. To understand the effect an increase in mesh size would have on catches, it is necessary to modify or replace all (or nearly all) traps in a fishery with the desired mesh size and follow the change in catch over several years.

The only experiments to look at longer-term effects of increased mesh sizes in the Caribbean showed that the mean catch weight per trap per haul for a 1.5 inch (3.8 cm) mesh one year after introduction was almost the same (0.83 kg) as that for the 1.25 inch (3.2 cm) mesh in the previous year (0.79 kg; Sary et al., 1997). Catch for the larger mesh traps increased to 1.24 kg three years after introduction. The mean length of Redband Parrotfish (*Sparisoma aurofrenatum*) was higher in the large mesh traps, indicating that the catch of juveniles and smaller individuals of this species was reduced (Sary et al., 1997).

Escape gaps

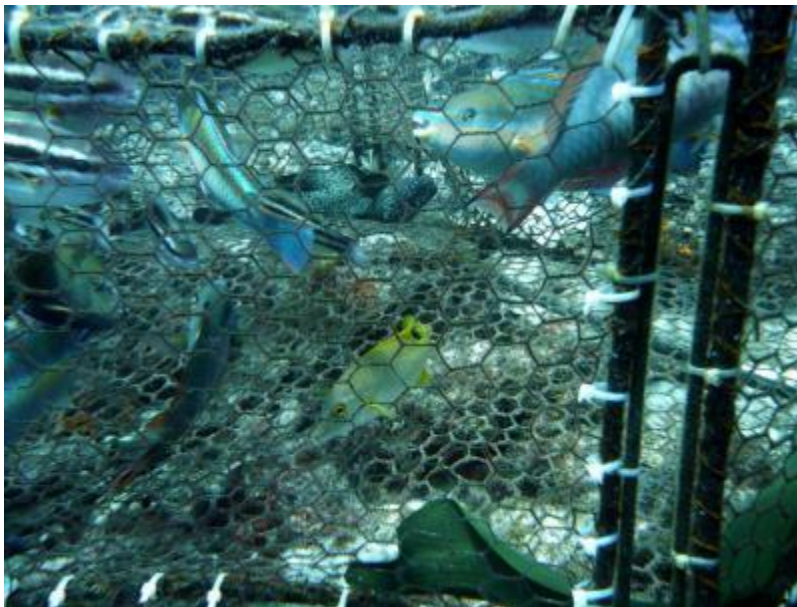

Figure 3. View of trap underwater with escape gap visible on the right hand-side of the image.
Photo: <https://www.rare.org/stories/2011-solution-search-winners>

Compared to mesh size, relatively little research has been published on the effects of escape gaps on trap catches (Johnson, 2010; Munro et al., 2003). Escape gaps are narrow slits that are built into a trap (Figure 3), with tested sizes varying from short gaps, e.g. 7 x 2.5 cm, to taller gaps, e.g. 40 x 2.5 cm, and widths varying from 2 cm to 8 cm (Baldwin et al., 2004; Condy et al., 2015; Johnson, 2010). The use of escape gaps offers a complementary or alternative approach to increased mesh size by adjusting the

size selectivity of traps and allowing juveniles and narrow-bodied fish to escape. The few research studies that have evaluated the use of escape gaps have found the value of catches may be maintained or reduced in the short-term and increased in the longer-term.

The most recent Caribbean study, in Curaçao, tested short escape gaps (20 x 2.5 cm) and tall escape gaps (40 x 2.5cm). Both sizes resulted in decreased catches of key herbivores (-58% and -50%, respectively) and bycatch species, such as butterflyfish and damselfish (-74% and -80%), and increases in the mean length of fish caught (Johnson, 2010). Furthermore, no significant reduction in the catch of high-value fish or market value of the catch was found with these escape gaps, though mean weight of the total catch was reduced.

These results are generally consistent with two studies based in Kenya that examined the performance of traps with escape gaps of varying sizes (Condy et al., 2015; Gomes et al., 2014). Both Kenya studies found reductions in the abundance of juvenile fish in the catch and an increased proportion of more commercially valuable adult species. One of these studies predicted a decline in profitability in the first year if escape gaps were implemented, with an increase in following years (Condy et al., 2015). The second study found no change in value of the catch in heavily fished areas and an increase in value in less depleted areas (Gomes et al., 2014).

Escape panels

In some fisheries 20-30% of traps are lost, abandoned, or discarded per year (NOAA Marine Debris Program, 2015), resulting in millions of ghost fishing traps worldwide (Scheld et al., 2016). Escape panels, which are weighted panels with a biodegradable fastener, have emerged as the best option for reducing the impacts of ghost fishing by traps (Stewart, 2007; Selliah et al., 2001; Fig. 4). Hemp twine has been shown to be the most suitable material for the fastener within the Caribbean (Selliah et al., 2001). Escape panels tied with hemp twine and weighted to help the panel fall open, opened after 22 - 26 days during testing (Selliah et al., 2001).

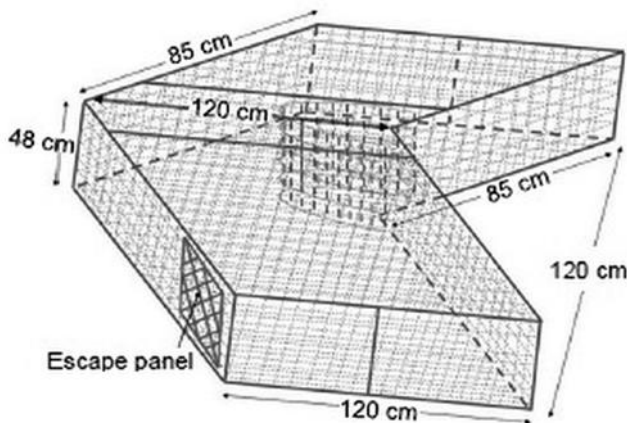

Figure 4. Arrowhead trap showing escape panel (after Renchen et al. 2014)

The only Caribbean study on the effects of trap ghost fishing took place in the U.S. Virgin Islands (U.S.V.I.) and documented a 2% mortality rate for trapped fish (Renchen et al., 2014). Another study in Florida, not specifically focused on ghost fishing, found that 27% of fish were dead or injured in traps left

for 20 days, and 17% of fish in traps left for two months were dead or injured (Taylor and McMichael, Jr., 1983). Neither experiment includes estimates of fish mortality through predation and scavenging within the cage, which may be a significant (Munro et al., 1971; Rassweiler and Rassweiler, 2011). Estimates of trap losses are variable with 10% of traps estimated to be lost each year in the U.S.V.I. (Renchen et al., 2014) and 15-20% lost per 20-day trip in the Tortugas, Florida (Taylor and McMichael, Jr., 1983). The use of escape panels was found to reduce fish mortality to near zero (Renchen et al., 2014). Escape panels are required by law in all traps used in Barbados (Baldwin et al., 2004), Curaçao, Puerto Rico and the U.S. Virgin Islands (NOAA, CFMC, 2015).

Gear retrieval

One option to further reduce ghost fishing pressure in an area, is to remove traps that have been abandoned or lost at sea. In Chesapeake Bay, the removal of 34,408 derelict crab pots (9% of derelict gear in Virginia waters) led to an estimated additional 13,504 MT of harvest (27% more than if no removals had occurred) with a value of US \$21.3 million (Scheld et al., 2016). In addition to contributing to fish mortality, derelict gear can cause mortality and injuries of marine mammals and turtles (Stokes et al., 2011).

Finding and removing derelict fishing gear (nets, traps, and other gear that has been discarded, abandoned, or lost) is challenging, but several studies have used side-scan sonar, Scuba diver surveys, and towed cameras to locate traps (Arthur et al., 2014). The success of these methods is dependent on several factors. Scuba surveys and cameras are generally only effective in shallow, clear waters (though cameras on remotely operated vehicles can be used in deeper waters), and sonar is less effective in areas with rugose-bottom environments (Arthur et al., 2014). Once located, divers can retrieve derelict gear, though care is required that they do not become entangled and that damage to sensitive substrates is minimized. Another option is to use a grappling hook suspended from a boat to attempt to snag gear and then pull it to the surface. In cases where the trap has become substantially encrusted with corals or other benthic organisms, but is no longer ghost fishing, there may be cause to leave traps in place.

To encourage fishers not to dispose of their gear at sea, there should be affordable facilities at ports for proper disposal of fishing gear, or even incentive programs (NOAA Marine Debris Program, 2015). For example, the Republic of Korea offers about US\$10 per 100 liter bag of fishing gear as an incentive for the proper disposal of gear, and collected 5,137 tonnes of gear in 2006 (Macfadyen et al., 2009). Similar schemes could help reduce disposal of gear at sea within the Caribbean.

Spearfishing

Description of gear and use

Spearfishing normally involves the use of a rubber-propelled spear operated by a person swimming at or below the surface (Ennis and Aiken, 2014; Frisch et al., 2007). Spearfishers commonly free dive (dive without tanks; Fig. 5) but may also use scuba or hookah equipment (surface-supplied air systems). Despite being banned or regulated on many islands, few published studies or descriptions exist on spearfishing in the Caribbean (Gillett and Moy, 2006). One of the few studies to quantify spearfishing in the region estimates that the proportion of spearfishers in Jamaica has grown from 1% of all types of fishers in 1991 to 10% in 2011 (Ennis and Aiken, 2014). Landings from spearfishers are likely an under-recorded portion of reef fishery landings, as demonstrated in Barbados where one study estimated that annual landings from spearfishing exceeded the official landings total for the entire reef fishery (Simpson et al., 2013).



Figure 5. Spearfisher with catch of reef fish at Glitter Bay, Barbados. Photo credit: David Gill

Biological and ecosystem impacts

Spearfishing can be an efficient method of harvesting fish. It is highly selective as spearfishers are able to target species and sizes of fish directly, which results in much lower bycatch compared to other fishing methods (Dalzell, 1996; Frisch et al., 2012). While this is good news for non-target species, this selectivity can lead to reductions in the mean size and abundance of target species (Chapman and Kramer, 1999; Frisch et al., 2012). Such changes are exemplified by a study on the Great Barrier Reef that found a 54% reduction in density and a 27% reduction in mean size of coral trout (*Plectropomus* spp.) three years after spearfishing was first permitted (Frisch et al., 2012). Although the targeting of larger individuals generally avoids the problem of removing fish before they are able to reach maturity, the largest (oldest) fish often have greater reproductive potential in the form of greater numbers of eggs produced and higher survival rates in their larvae, compared to younger fish. (Birkeland and Dayton, 2005).

Large fish have other ecosystem benefits as well. For example, large parrotfish have a disproportionately greater algal grazing intensity than small parrotfish. As noted previously, herbivores such as parrotfish are vital to the maintenance of reefs in a coral-dominated state (Mumby et al., 2006). As such, the impacts of reduced grazing intensity might be particularly severe in areas where parrotfish are targeted directly, such as Barbados (Simpson et al., 2013).

Management options

Current management of spearfishing in the Caribbean has focused on total bans on spearfishing gear and bans on spearfishing while on scuba or hookah, as well as regulations requiring spearfishers to obtain permits (Gillett and Moy, 2006; McManus and Lacambra, 2005). Bans on spearfishing at night have also been implemented as some species of reef fish sleep on the reef at night and therefore make easy targets. Jamaica and many places in the Pacific prohibit spearfishing at night, though these bans are difficult to enforce (Ennis and Aiken, 2014; Gillett and Moy, 2006). In areas where tourism is a significant source of income, there may be support for total bans on spearfishing, e.g. the Dutch Caribbean and U.S. Virgin Islands already ban spearfishing (Gillett and Moy, 2006). These bans can help protect reef biodiversity which tourists, especially dive tourists, want to see (Gill et al., 2015; Uyarra et al., 2005). Many Caribbean countries that do not have bans are considering one (Gillett and Moy, 2006).

Lionfish spearfishing – new opportunities

In Bonaire, where spearfishing has been banned, the national parks authority has issued permits to recreational divers that allow them to use a modified spear gun to kill lionfish (de León et al., 2013).

Lionfish are an invasive species within the Caribbean and can have significant ecosystem impacts. The lionfish preys on a wide diversity of reef fishes and can rapidly decrease the biomass of their prey (Albins and Hixon, 2011; Green et al., 2012), and, with no local predators, their population growth has been explosive (Green and Côté, 2008).

To reduce lionfish populations, sustained removals are required (Barbour et al., 2011) and therefore there may be the potential to develop lionfish fisheries. Any attempts to develop such a fishery should proceed carefully, as spearfishing of lionfish can still have negative impacts such as physical damage to reefs from divers and their spears, and, in areas where spearfishing has been banned, spearfishers may poach other species. There is also concern that lionfish can contain the ciguatera toxin, a lipid soluble toxin produced by microalgae, that can cause poisoning in humans (Dickey and Plakas, 2010). However, no cases of poisoning due to lionfish consumption have been reported within the Caribbean (Wilcox and Hixon, 2014). Despite these potential issues, if properly regulated, a targeted lionfish fishery could potentially benefit the reef ecosystem in addition to providing a new fish species for market.

Hook and line



Figure 6. Fishing line with rock as weight being prepared for fishing in Tobago. Note multiple baited hooks. Photo credit: Jason Flower

Description of gear and use

Hook and line fishing ('line fishing') refers to the use of a fishing line (made from natural or synthetic material) with a hook or hooks attached which may be baited. 'Bottom fishing', a type of line fishing common in and around reefs, entails a weighted line and one or more baited hooks lowered to the seafloor (Fig. 6; Munro, 1983). Target species are generally demersal reef species and deep slope species, such as groupers and snappers (Mumby et al., 2014), and fishing depths can range from shallow reefs (< 45 m) to deep banks that may be in 30-250 m of water (Munro, 1983). Line fishing for pelagic species such as tunas and Wahoo is also practiced using a variety of methods; however, these are not covered here as they are not generally associated with reefs. In the 1980s, line fishing was the second most important method of reef fish exploitation in the Caribbean (Munro, 1983), and national reports from some countries, such as Grenada and Jamaica, suggest this may still be the case today (CRFM, 2014).

Biological and ecosystem impacts

Line fishing is the least regulated of all fishing methods in the Caribbean and little information is available on its impacts on coral reefs. Compared to trap fishing and beach seining, line fishing's direct physical impact on habitat is minimal, although the weight used to keep the line vertical and the line itself may cause damage to corals and other benthic organisms (Chiappone et al., 2002). Additionally, fishing lines can entangle marine mammals and turtles, and hooks can be ingested causing injuries and mortality (Stokes et al., 2011). Line fishing catches from reefs generally avoid ecologically important herbivores and are composed mainly of snappers, groupers, and grunts (Dalzell, 1996).

Management options

Circle hooks can reduce the injury to and mortality of juvenile and other non-target fish that are inadvertently captured and then released. Circle hooks are similar to the more commonly used J hooks (Fig. 7), but the point is turned back towards the shank forming a generally circular shape (Cooke and Suski, 2004). They have been shown to reduce the mortality rates for several species when compared to J hooks by more frequently hooking fish in the jaw rather than in the gut (Cooke and Suski, 2004; Sauls and Ayala, 2012). The use of circle hooks was mandated in the U.S. federal waters of the Gulf of Mexico in 2007 in an effort to reduce bycatch mortality (Garner et al., 2014). Hook size can also affect the size of species caught and catch composition, and there is some evidence larger hook sizes increase the mean length of the catch. However, larger hooks may also reduce catch rates (Garner et al., 2014; Sauls and Ayala, 2012).

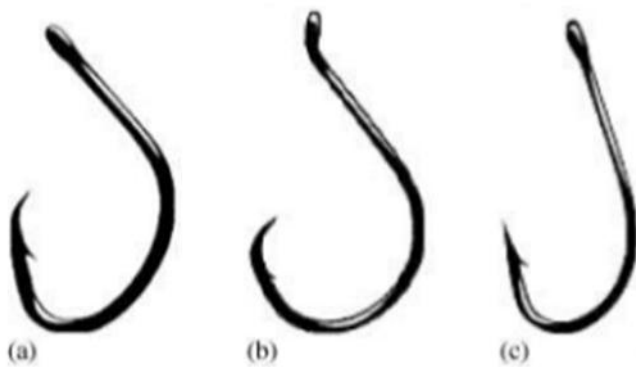

Figure 7. Two circle hook designs (a,b) and a conventional J-style hook (c) (after Cooke and Suski, 2004)

Beach Seine

Description of gear and use

Beach seine nets consist of a rectangular wall of netting (Fig. 8) that is held vertical in the water by floats at the surface and weights at the bottom (Adams, 1993). One end of the net is held at the beach while the rest of the net is played out by a boat, setting the net in a semi-circle around the targeted fish. The boat brings the other end of the net in further down the shoreline and the net is pulled in towards the shore in an ever decreasing semi-circle that encloses the fish. Nets can be tens to hundreds of meters long (Adams, 1993;



Figure 8. Sorting a beach seine catch in Charlotteville, Tobago. Photo credit: Jason Flower

Maraj et al., 2011). The main species caught by beach seines include small coastal pelagic species such as scads (*Decapterus* spp. and *Selar crumenophthalmus*) and small jacks (*Caranx* spp.) as well as small demersal species and immature reef fishes. Beach seine nets are commonly used throughout the Lesser Antilles (CRFM, 2014; Mahon, 1993; Munro, 1983).

Biological and ecosystem impacts

Two impacts are of particular concern with the use of beach seines: the non-selective nature of the nets and habitat damage caused by dragging gear. Seine nets catch a high diversity of fish and many juveniles (Mangi and Roberts, 2006; McClanahan and Mangi, 2004). In Kenya, more than two-thirds of beach seine catches were composed of juvenile fish (Mangi and Roberts, 2006). In the same study, researchers found that beach seine use impacted coral cover and diversity, as the nets and team of fishers (including snorkelers) came into contact with corals. Although fishers using beach seine will not actively target rocky substrate, such as reefs, nearshore areas in the Caribbean often have cover of seagrass and corals, and setting and dragging a seine net through these can result in significant damage and loss of habitat.

Management options

In areas in Kenya where beach seines have been banned, other fishing gears have shown increases in catches (McClanahan, 2010). A total ban may not be an option in places where beach seine fishing is an important source of income and protein (Fanning and Oxenford, 2011). In these instances, policymakers could prohibit seining in coral and seagrass beds to avoid damage to those habitats, e.g. Barbados bans the use of beach seines near coral reefs (McManus and Lacambra, 2005). As with traps, a minimum mesh size for seine nets could help reduce the proportion of juvenile fish in catches. Several countries in the Caribbean have regulated the mesh size of beach seine nets. In St. Lucia, the minimum mesh size is 31.75 mm (1.25 inches), while Antigua and Barbuda as well as Barbados have a 38.1 mm (1.5 inches) minimum mesh size (McManus and Lacambra, 2005).

References

- Adams, J.E., 1993. Beach seining in the West Indies. *Caribb. Q.* 39, 44–55.
- Albins, M.A., Hixon, M.A., 2011. Worst case scenario: potential long-term effects of invasive predatory lionfish (*Pterois volitans*) on Atlantic and Caribbean coral-reef communities. *Environ. Biol. Fishes* 96, 1151–1157. doi:10.1007/s10641-011-9795-1
- Arthur, C., Sutton-Grier, A.E., Murphy, P., Bamford, H., 2014. Out of sight but not out of mind: Harmful effects of derelict traps in selected U.S. coastal waters. *Mar. Pollut. Bull.* 86, 19–28. doi:10.1016/j.marpolbul.2014.06.050
- Baldwin, K., Oxenford, H.A., Parker, C., Franklin, G., 2004. Comparing juvenile catch rates among conventional fish traps and traps designed to reduce fishing mortality on juvenile reef fishes, in: *Proceedings of the 55th Gulf and Caribbean Fisheries Institute Conference*.
- Barbour, A.B., Allen, M.S., Frazer, T.K., Sherman, K.D., 2011. Evaluating the Potential Efficacy of Invasive Lionfish (*Pterois volitans*) Removals. *PLOS ONE* 6, e19666. doi:10.1371/journal.pone.0019666
- Beger, M., McGowan, J., Treml, E.A., Green, A.L., White, A.T., Wolff, N.H., Klein, C.J., Mumby, P.J., Possingham, H.P., 2015. Integrating regional conservation priorities for multiple objectives into national policy. *Nat. Commun.* 6, 8208. doi:10.1038/ncomms9208
- Birkeland, C., Dayton, P.K., 2005. The importance in fishery management of leaving the big ones. *Trends Ecol. Evol.* 20, 356–358. doi:10.1016/j.tree.2005.03.015

- Bohnsack, J.A., Sutherland, D.L., Harper, D.E., McClellan, D.B., Hulsbeck, M.W., Holt, C.M., 1989. The effects of fish trap mesh size on reef fish catch off southeastern Florida. *Mar. Fish. Rev.* 51, 36–46.
- Bozec, Y.-M., O’Farrell, S., Bruggemann, J.H., Luckhurst, B.E., Mumby, P.J., 2016. Tradeoffs between fisheries harvest and the resilience of coral reefs. *Proc. Natl. Acad. Sci.* 113, 4536–4541. doi:10.1073/pnas.1601529113
- Burke, L., Raytar, K., Spalding, M., Perry, A., 2011. Reefs at risk revisited. World Resources Institute, World Resources Institute, Washington DC.
- Chapman, M.R., Kramer, D.L., 1999. Gradients in coral reef fish density and size across the Barbados Marine Reserve boundary: effects of reserve protection and habitat characteristics. *Mar. Ecol. Prog. Ser.* 181, 81–96. doi:10.3354/meps181081
- Chiappone, M., White, A., Swanson, D.W., Miller, S.L., 2002. Occurrence and biological impacts of fishing gear and other marine debris in the Florida Keys. *Mar. Pollut. Bull.* 44, 597–604.
- Cinner, J.E., McClanahan, T.R., Graham, N.A.J., Pratchett, M.S., Wilson, S.K., Raina, J.-B., 2009. Gear-based fisheries management as a potential adaptive response to climate change and coral mortality. *J. Appl. Ecol.* 46, 724–732. doi:10.1111/j.1365-2664.2009.01648.x
- Condy, M., Cinner, J.E., McClanahan, T.R., Bellwood, D.R., 2015. Projections of the impacts of gear-modification on the recovery of fish catches and ecosystem function in an impoverished fishery. *Aquat. Conserv. Mar. Freshw. Ecosyst.* 25, 396–410. doi:10.1002/aqc.2482
- Cooke, S.J., Suski, C.D., 2004. Are circle hooks an effective tool for conserving marine and freshwater recreational catch-and-release fisheries? *Aquat. Conserv. Mar. Freshw. Ecosyst.* 14, 299–326. doi:10.1002/aqc.614
- CRFM, 2014. Report of Tenth Annual CRFM Scientific Meeting – Kingstown, St. Vincent & the Grenadines, 10-17 June 2014 - National Reports (CRFM Fishery Report No. Volume 1, Suppl. 1).
- Dalzell, P., 1996. Catch rates, selectivity and yields of reef fishing, in: Polunin, N.V., Roberts, C.M. (Eds.), *Reef Fisheries*. Chapman and Hall, London, pp. 161–192.
- de León, R., Vane, K., Bertuol, P., Chamberland, V.C., Simal, F., Imms, E., Vermeij, M.J.A., 2013. Effectiveness of lionfish removal efforts in the southern Caribbean. *Endanger. Species Res.* 22, 175–182. doi:10.3354/esr00542
- Dickey, R.W., Plakas, S.M., 2010. Ciguatera: A public health perspective. *Toxicon* 56, 123–136. doi:10.1016/j.toxicon.2009.09.008
- Ennis, Z., Aiken, K., 2014. Spearfishing as a potential threat to fishery sustainability in Jamaica: a survey of 23 fishing beaches. *Rev. Biol. Trop.* 62, 392–400.
- Fanning, L., Oxenford, H.A., 2011. Ecosystem issues pertaining to the flyingfish (*Hirundichthys affinis*) fisheries of the eastern Caribbean, in: Fanning, L., Mahon, R., McConney, P. (Eds.), *Towards Marine Ecosystem-Based Management in the Wider Caribbean*. Amsterdam University Press.
- Frisch, A.J., Baker, R., Hobbs, J.-P.A., Nankervis, L., 2007. A quantitative comparison of recreational spearfishing and linefishing on the Great Barrier Reef: implications for management of multi-sector coral reef fisheries. *Coral Reefs* 27, 85–95. doi:10.1007/s00338-007-0293-z
- Frisch, A.J., Cole, A.J., Hobbs, J.-P.A., Rizzari, J.R., Munkres, K.P., 2012. Effects of Spearfishing on Reef Fish Populations in a Multi-Use Conservation Area. *PLOS ONE* 7, e51938. doi:10.1371/journal.pone.0051938
- Gaines, S.D., White, C., Carr, M.H., Palumbi, S.R., 2010. Designing marine reserve networks for both conservation and fisheries management. *Proc. Natl. Acad. Sci. U. S. A.* 107, 18286–18293. doi:10.1073/pnas.0906473107
- Garner, S.B., III, W.F.P., Porch, C.E., Tarnecki, J.H., 2014. Experimental Assessment of Circle Hook Performance and Selectivity in the Northern Gulf of Mexico Recreational Reef Fish Fishery. *Mar. Coast. Fish.* 6, 235–246. doi:10.1080/19425120.2014.952463

- Garrison, V., Beets, J., 1998. Of reef fishes, overfishing and in situ observations of fish traps in St. John, U.S. Virgin Islands. *Rev. Biol. Trop.* 46, 41–59.
- Gill, D.A., Schuhmann, P.W., Oxenford, H.A., 2015. Recreational diver preferences for reef fish attributes: Economic implications of future change. *Ecol. Econ.* 111, 48–57.
doi:10.1016/j.ecolecon.2015.01.004
- Gillett, R., Moy, W., 2006. Spearfishing in the Pacific Islands. Current status and management issues (No. 19). FAO/ FishCode Review, Rome.
- Gomes, I., Erzini, K., McClanahan, T.R., 2014. Trap modification opens new gates to achieve sustainable coral reef fisheries: Escape gap's in African traditional trap fisheries. *Aquat. Conserv. Mar. Freshw. Ecosyst.* 24, 680–695. doi:10.1002/aqc.2389
- Graham, N.A., Bellwood, D.R., Cinner, J.E., Hughes, T.P., Norström, A.V., Nyström, M., 2013. Managing resilience to reverse phase shifts in coral reefs. *Front. Ecol. Environ.* 11, 541–548.
doi:10.1890/120305
- Green, S.J., Akins, J.L., Maljković, A., Côté, I.M., 2012. Invasive Lionfish Drive Atlantic Coral Reef Fish Declines. *PLOS ONE* 7, e32596. doi:10.1371/journal.pone.0032596
- Green, S.J., Côté, I.M., 2008. Record densities of Indo-Pacific lionfish on Bahamian coral reefs. *Coral Reefs* 28, 107–107. doi:10.1007/s00338-008-0446-8
- Hawkins, J.P., Roberts, C.M., Gell, F.R., Dytham, C., 2007. Effects of trap fishing on reef fish communities. *Aquat. Conserv. Mar. Freshw. Ecosyst.* 17, 111–132. doi:10.1002/aqc.784
- Hicks, C.C., McClanahan, T.R., 2012. Assessing Gear Modifications Needed to Optimize Yields in a Heavily Exploited, Multi-Species, Seagrass and Coral Reef Fishery. *PLOS ONE* 7, e36022.
doi:10.1371/journal.pone.0036022
- Jackson, J., Donovan, M., Cramer, K., Lam, V., 2014. Status and trends of Caribbean coral reefs: 1970-2012. Global Coral Reef Monitoring Network.
- Jackson, J.B., 1997. Reefs since columbus. *Coral Reefs* 16, S23–S32.
- Jiménez, A.R., Sadovy, Y., 1996. The effect of fish trap mesh size on species composition and catch value in Western Puerto Rico, in: Proceedings of the 44th Gulf and Caribbean Fisheries Institute. Presented at the Gulf and Caribbean Fisheries Institute.
- Johnson, A.E., 2010. Reducing bycatch in coral reef trap fisheries: escape gaps as a step towards sustainability. *Mar. Ecol. Prog. Ser.* 415, 201–209. doi:10.3354/meps08762
- Macfadyen, G., Huntington, T., Cappell, R., 2009. Abandoned, lost or otherwise discarded fishing gear, UNEP Regional Seas Reports and Studies No.185; FAO Fisheries and Aquaculture Technical Paper, No. 523. Rome.
- Mahon, R., 1997. Does fisheries science serve the needs of managers of small stocks in developing countries. *Can. J. Fish. Aquat. Sci.* 54, 2207–2213. doi:10.1139/f97-112
- Mahon, R., 1993. Lesser Antilles, in: Marine Fishery Resources of the Antilles: Lesser Antilles, Puerto Rico and Hispaniola, Jamaica, Cuba, FAO Fisheries Technical Paper. FAO, Rome.
- Mahon, R., Hunte, W., 2001. Trap mesh selectivity and the management of reef fishes. *Fish Fish.* 2, 356–375.
- Mangi, S.C., Roberts, C.M., 2006. Quantifying the environmental impacts of artisanal fishing gear on Kenya's coral reef ecosystems. *Mar. Pollut. Bull.* 52, 1646–1660.
doi:10.1016/j.marpolbul.2006.06.006
- Maraj, V., Cox, S.A., Oxenford, H.A., 2011. Current status of the small-scale seine fishery in Barbados, in: Proceedings of the 63rd Gulf and Caribbean Fisheries Institute. San Juan, Puerto Rico, pp. 411–419.
- Marshak, A.R., Hill, R.L., Sheridan, P., Schärer, M.T., Appeldoorn, R., 2007. In-situ observations of Antillean fish trap contents in Southwest Puerto Rico: Relating catch to habitat and damage

- potential, in: Proceedings of the 60th Gulf and Caribbean Fisheries Institute. Punta Cana, Dominican Republic, pp. 447–453.
- McClanahan, T.R., 2010. Effects of Fisheries Closures and Gear Restrictions on Fishing Income in a Kenyan Coral Reef: Area Closures and Fishing Income. *Conserv. Biol.* 24, 1519–1528. doi:10.1111/j.1523-1739.2010.01530.x
- McClanahan, T.R., Cinner, J., Kamukuru, A.T., Abunge, C., Ndagala, J., 2008. Management preferences, perceived benefits and conflicts among resource users and managers in the Mafia Island Marine Park, Tanzania. *Environ. Conserv.* 35, 340–350. doi:10.1017/S0376892908005250
- McClanahan, T.R., Cinner, J.E., 2008. A framework for adaptive gear and ecosystem-based management in the artisanal coral reef fishery of Papua New Guinea. *Aquat. Conserv. Mar. Freshw. Ecosyst.* 18, 493–507. doi:10.1002/aqc.874
- McClanahan, T.R., Mangi, S.C., 2004. Gear-based management of a tropical artisanal fishery based on species selectivity and capture size. *Fish. Manag. Ecol.* 11, 51–60.
- McManus, E., Lacambra, C., 2005. Fishery regulations in the Wider Caribbean. United Nations Environment Program, World Conservation Monitoring Centre, Cambridge, U.K.
- Mumby, P., Flower, J., Chollett, I., Box, S., Bozec, Y., Fitzsimmons, C., Forster, J., Gill, D., Griffith-Mumby, R., Oxenford, H., 2014. Towards Reef Resilience and Sustainable Livelihoods. A Handbook for Caribbean Coral Reef Managers. University of Exeter, UK.
- Mumby, P.J., 2006. The impact of exploiting grazers (Scaridae) on the dynamics of Caribbean coral reefs. *Ecol. Appl. Publ. Ecol. Soc. Am.* 16, 747–769.
- Mumby, P.J., Dahlgren, C.P., Harborne, A.R., Kappel, C.V., Micheli, F., Brumbaugh, D.R., Holmes, K.E., Mendes, J.M., Broad, K., Sanchirico, J.N., Buch, K., Box, S., Stoffle, R.W., Gill, A.B., 2006. Fishing, Trophic Cascades, and the Process of Grazing on Coral Reefs. *Science* 311, 98–101. doi:10.1126/science.1121129
- Mumby, P.J., Harborne, A.R., 2010. Marine Reserves Enhance the Recovery of Corals on Caribbean Reefs. *PLOS ONE* 5, e8657. doi:10.1371/journal.pone.0008657
- Munro, J.L., 1983. Caribbean coral reef fishery resources (7), ICLARM Studies and Reviews. ICLARM.
- Munro, J.L., Reeson, P.H., Gaut, V.C., 1971. Dynamic factors affecting the performance of Antillean fish traps, in: Proceedings of the 23rd Gulf and Caribbean Fisheries Institute. Coral Gables, Florida, pp. 184–194.
- Munro, J.L., Sary, Z., Gell, F.R., 2003. Escape gaps: An option for management of Caribbean trap fisheries, in: Proceedings of the 54th Gulf and Caribbean Fisheries Institute Conference.
- NOAA, CFMC, 2015. Summary of Commercial and Recreational Fishing Regulations for the U.S. Caribbean Exclusive Economic Zone. NOAA, Caribbean Fishery Management Council.
- NOAA Marine Debris Program, 2015. Report on the impacts of “ghost fishing” via derelict fishing gear. NOAA, Silver Spring, MD.
- Rassweiler, A., Rassweiler, T., 2011. Does rapid scavenging hide non-predation mortality in coral-reef communities? *Mar. Freshw. Res.* 62, 510. doi:10.1071/MF10194
- Renchen, G.F., Pittman, S.J., Clark, R., Caldow, C., Gall, S., Olsen, D., Hill, R.L., 2014. Impact of derelict fish traps in Caribbean waters: an experimental approach. *Bull. Mar. Sci.* 90, 551–563. doi:10.5343/bms.2012.1103
- Salas, S., Chuenpagdee, R., Seijo, J.C., Charles, A., 2007. Challenges in the assessment and management of small-scale fisheries in Latin America and the Caribbean. *Fish. Res.* 87, 5–16. doi:10.1016/j.fishres.2007.06.015
- Sary, Z., Oxenford, H.A., Woodley, J.D., 1997. Effects of an increase in trap mesh size on an overexploited coral reef fishery at Discovery Bay, Jamaica. *Mar. Ecol. Prog. Ser.* 154, 107–120.

- Sauls, B., Ayala, O., 2012. Circle Hook Requirements in the Gulf of Mexico: Application in Recreational Fisheries and Effectiveness for Conservation of Reef Fishes. *Bull. Mar. Sci.* 88, 667–679. doi:10.5343/bms.2011.1055
- Scheld, A.M., Bilkovic, D.M., Havens, K.J., 2016. The Dilemma of Derelict Gear. *Sci. Rep.* 6, 19671. doi:10.1038/srep19671
- Selliah, N., Oxenford, H., Parker, C., 2001. Selecting biodegradable fasteners and testing the effects of escape panels on catch rates of fish traps, in: *Proceedings of the 52nd Gulf and Caribbean Fisheries Institute Conference*. pp. 634–653.
- Simpson, N., Oxenford, H.A., Gill, D., Turner, R., 2013. The spear fishery of Barbados, in: *Proceedings of the 66th Gulf and Caribbean Fisheries Institute*. Corpus Christi, Texas, USA, pp. 135–139.
- Stewart, J., 2007. By-catch reduction in wire-mesh fish traps, in: *By-Catch Reduction in the World's Fisheries*. Springer, pp. 75–93.
- Stokes, L.W., Hataway, D., Epperly, S.P., Shah, A.K., Bergmann, C.E., Watson, J.W., Higgins, B.M., 2011. Hook ingestion rates in loggerhead sea turtles *Caretta caretta* as a function of animal size, hook size, and bait. *Endanger. Species Res.* 14, 1–11. doi:10.3354/esr00339
- Taylor, R.G., McMichael, Jr., R.H., 1983. The wire fish-trap fisheries in Monroe and Collier Counties, Florida. *Fla. Mar. Res. Publ.* 39.
- Teh, L.S.L., Teh, L.C.L., Sumaila, U.R., 2013. A Global Estimate of the Number of Coral Reef Fishers. *PLOS ONE* 8, e65397. doi:10.1371/journal.pone.0065397
- Uyarra, M.C., Côté, I.M., Gill, J.A., Tinch, R.R.T., Viner, D., Watkinson, A.R., 2005. Island-specific preferences of tourists for environmental features: implications of climate change for tourism-dependent states. *Environ. Conserv.* 32, 11–19. doi:10.1017/S0376892904001808
- Wilcox, C.L., Hixon, M.A., 2014. False positive tests for ciguatera may derail efforts to control invasive lionfish. *Environ. Biol. Fishes* 98, 961–969. doi:10.1007/s10641-014-0313-0
- Wolf, R.S., Chislett, G.R., 1974. Trap fishing explorations for snapper and related species in the Caribbean and adjacent waters. *Mar Fish Rev* 36, 49–61.